

GE's Jenbacher gas engine division is one of the world's leading manufacturers of gas-fueled reciprocating engines, packaged generator sets and cogeneration units for power generation. It is one of the only companies in the world focusing exclusively on gas engine technology.

GE's Jenbacher gas engines range in power from 0.25 to 4 MW and run on either natural gas or a variety of other gases (e.g., biogas, landfill gas, coal mine gas, sewage gas, combustible industrial waste gases).

A broad range of commercial, industrial, and municipal customers use Jenbacher products for on-site generation of power, heat, and cooling. Patented combustion systems, engine controls, and monitoring enable its power generation plants to meet stringent emission standards, while offering high levels of efficiency, durability, and reliability.

GE's Jenbacher product team has its headquarters, main production facilities, and 1,300 of its about 1,700 worldwide employees in Jenbach, Austria. GE also operates two regional gas engine assembly facilities in Hangzhou, China, and in Veresegyház, Hungary.



ZIMMERMANN PUPP

GEA-1.137.17A-R1

for more information on Jenbacher gas engines

Austria (Headquarters)

Achenseestraße 1-3
6200 Jenbach
T +43 5244 600-0
F +43 5244 600-527
jenbacher.info@ge.com
www.gejenbacher.com

Brazil

Rod. Jornalista Frco. Aguirre Proenca
s/n Km 3,8 - Boa Vista
13064-654 Campinas-SP
T +55 19 2104 6996
F +55 19 2104 6999
jenbacher.brazil@ge.com

Bulgaria

36, Dragan Tsankov Blvd.
1040 Sofia
T +359 2 971 4390
F +359 2 971 4384
jenbacher.bulgaria@ge.com

China

288 Hongxing Rd., South Bridge
Xiaoshan Economic & Tech. Development Zone
Hangzhou, 311231, P.R. China
T +86 571 8369 9888
F +86 571 8286 9107
jenbacher.china@ge.com

18/F., Kerry Center

1 Guanghua Road, Chaoyang District
Beijing 100020
T +8610 5822 3821
F +8610 8529 6283

Denmark

Samsøvej 10
8382 Hinnerup
T +45 86966788
F +45 86967072
jenbacher.scandinavia@ge.com

Germany

Carl-Benz-Str. 25
67227 Frankenthal
T +49 6233 5110-0
F +49 6233 5110-170
jenbacher.germany@ge.com

Hungary

Kisret út 1
2112 Veresegyház
T +36 2858 7376
F +36 2858 7491
jenbacher.hungary@ge.com

India

A-1, 2nd Floor, Golden Enclave
Corporate Towers, Airport Road
560 017 Bangalore
T +91 80 4150 1406
F +91 99452 01125
jenbacher.india@ge.com

Italy

Via Crocioni, 46/H
37012 Bussolengo (VR)
T +39 045 6760211
F +39 045 6766322
jenbacher.italy@ge.com

North America

5244 North Sam Houston Pkwy E.
Houston, TX 77032
T +1 832 2955600
F +1 281 4429994
jenbacher.us@ge.com

Russia

27, Electrozavodskaya Street, bld. 8, floor 5
107023 Moscow
T +7 495 937 1111, +7 495 981 1313
F +7 495 937 1112
jenbacher.russia@ge.com

Singapore

240 Tanjong Pagar Road, GE Tower
88540 Singapore
T +65 6326 3659
F +65 6326 3623
jenbacher.singapore@ge.com

Spain and Portugal

Avda. del Camino de lo Cortao, 34 - Nave 8
28703 San Sebastián de los Reyes (Madrid)
T +34 916586800
F +34 916522616
jenbacher.iberica@ge.com

South Africa

Unit 5 Corporate Park, 130 Gazelle Avenue
1685 Midrand
T +27 11 237 0125
F +27 86 532 5987
jenbacher.southafrica@ge.com

The Netherlands

Kelvinring 58
2952 BG Alblasterdam
T +31 (0)88 0019700
F +31 (0)88 0019701
jenbacher.netherlands@ge.com



Generating power and heat,
wherever you need it.

On-site power supply
with Jenbacher gas engines.

ecomagination
a GE commitment

© 2011 GE Jenbacher GmbH & Co OHG. All rights reserved.

cogeneration of heat and power

Cogeneration systems – also called combined heat and power or CHP systems – generate both heat and power. Jenbacher CHP systems economically utilize the waste heat incurred during engine operation to generate overall plant efficiencies of more than 90%. This efficient form of energy conversion achieves primary energy savings of roughly 40% by using a gas engine cogeneration system instead of separate power and heat generation equipment. Transportation and distribution losses are also reduced or eliminated as the decentralized energy supply is set up where it is needed.

the Jenbacher concept

The basic structure of a Jenbacher CHP system consists of an engine/generator unit and heat exchangers for the utilization of waste heat. The incorporation of a wide range of heat sources – from engine cooling water, oil and air/fuel gas mixture to exhaust gas – is configured to maximize the benefit to each individual customer.

Cogeneration systems can be supplemented with a boiler system for bridging peak heat demand periods. An additional increase in the operating time and efficiency of the system is made possible

by the connection of a heat storage medium. Power plant electrical switch and control systems distribute the electricity and manage the engine, while hydraulic equipment ensures the heat distribution.

The generated power is utilized by the individual facilities (e.g., hospitals) or fed into the public power grid. The thermal energy can be used for both generating heating water and steam production as well as for various types of process heat. Gas engine cogeneration systems are also used for CO₂ fertilization in greenhouses and trigeneration systems (combined generation of heat, cooling, and power).

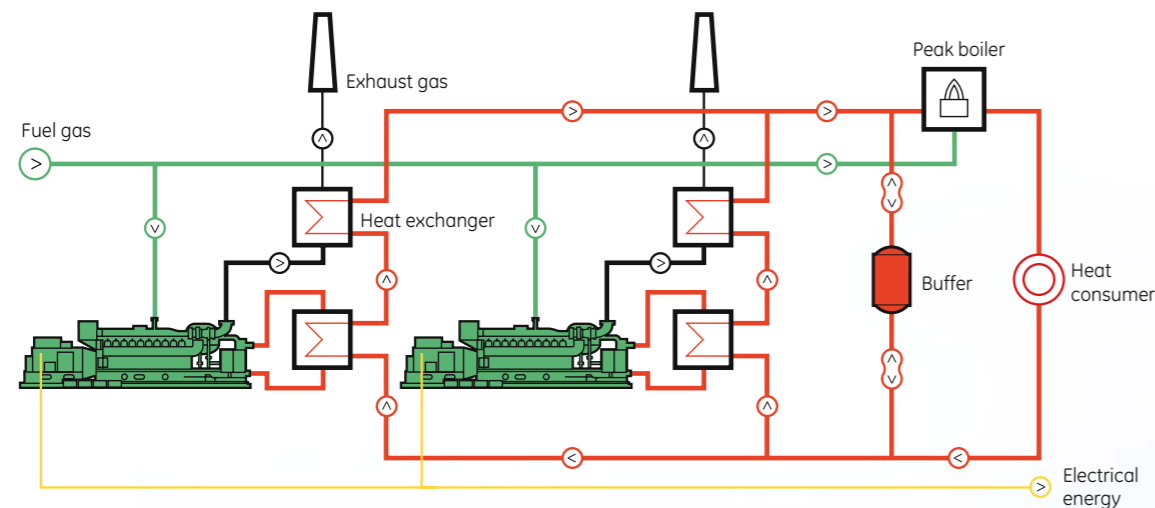

advantages of Jenbacher cogeneration systems

- High electrical efficiencies of up to 44%
- Overall efficiencies (electrical and thermal) of over 90%
- Wide range of power and heat outputs
- Minimum emissions through the patented LEANOX® lean mixture combustion
- Compact design requires a comparatively small footprint
- Specially designed engines for utilization of alternative energy sources (e.g., biogas, landfill gas, coal mine gas, or coke gas)
- Maximum operational safety and availability
- Low investment costs

key figures

A cogeneration plant with 1,000 kWel and 1,250 kWth can meet the following heat demands:

- Short-distance heating network approximately 12,500 m² of residential area
- Hospital approximately 150 beds
- Building supply approximately 10,000 m² of useful area (floor space)

our competence

The first Jenbacher gas engine was built in 1957. Today, more than 4,300 natural gas-fueled Jenbacher cogeneration plants with a total electrical output of about 6,200 MW have been delivered worldwide. Increases in energy costs, environmental concerns and energy demands will continue to promote the future growth of CHP systems, with Jenbacher innovative cogeneration systems leading the way.

These plants generate more than 37 million MW-hours of electricity a year – enough to supply over 9 million EU homes – and more than 33 million MW-hours of heat – enough to supply 3.3 millions EU homes. Compared to the separate generation of the same amount of heat and power, the avoided primary energy input is equivalent to the energy contained in almost 38 million barrels of oil. In addition, by using a gas engine cogeneration system instead of separate power and heat generation equipment, 2.3 million tons of CO₂ savings can be achieved. This amount of greenhouse gas emission savings equals to the annual CO₂ emissions emitted by 1.1 million EU passenger cars.

Jenbacher natural gas-fueled cogeneration gas engines are ecomagination approved. Ecomagination is GE's corporate-wide initiative to aggressively bring to market technologies that help customers meet pressing environmental challenges. GE Jenbacher's natural gas-fired cogeneration gas engines received ecomagination certification for their ability to provide customers with a cost-effective, high output means of generating power while substantially and measurably reducing their operating emissions. For more information on ecomagination please visit our website at www.ecomagination.ge.com

