

Specifications and Ordering Information

330750 and 330752

High Temperature Velomitor® System

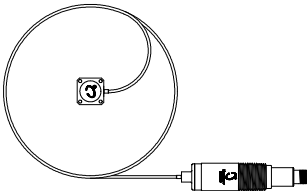

Description

The standard 330500 Velomitor® Piezo-velocity Sensor has a limited temperature range it can be exposed to, due to its signal conditioning electronics being located in the same case as the sensing element. Temperature limitations of the electronics limit its maximum operating temperature to +121°C (+250°F).

The 330750 and 330752 High Temperature Velomitor® System (HTVS) has a fundamentally different construction to solve this problem. Its design segregates the sensing element from the signal conditioning electronics, with the two permanently connected via a hardline cable. Current versions (see note below) of these sensors allow the sensing head to be mounted on surfaces with temperatures as high as +400°C (+752°F). Due to the segregated design, the signal conditioning electronics can be installed in a cooler location. This achieves overall transducer system performance comparable to other Velomitor® transducers, but permits use at significantly higher temperatures. By eliminating connections between the sensing head and its associated signal conditioning electronics, a significant source of potential transducer failures (connector problems) is eliminated.

Caution

If housing measurements are being made for overall protection of the machine, thought should be given to the usefulness of the measurement for each application. Most common machine malfunctions (imbalance, misalignment, etc.) originate at the rotor and cause an increase (or at least a change) in rotor vibration. In order for any housing measurement alone to be effective for overall machine protection, a significant amount of rotor vibration must be faithfully transmitted to the bearing housing or machine casing, or more specifically, to the mounting location of the transducer.

In addition, care should be exercised in the physical installation of the transducer. Improper installation can result in a degradation of the transducer's performance, and/or the generation of signals which do not represent actual machine vibration.

Upon request, Bently Nevada can provide engineering services to determine the appropriateness of housing measurements for the machine in question and/or to provide installation assistance.

Note: The previous version limited the sensor head to +300°C (+572°F). The current versions will have the letter "G" preceding the serial number.



Specifications

Parameters are specified from +20 to +30°C (+68 to +86°F) and 100Hz unless otherwise indicated.

Note: Operation outside the specified limits may result in false readings or loss of machine monitoring.

Electrical

<i>Sensitivity:</i>	5.7 mV/mm/s (145 mV/in/s) ±5%
<i>Frequency response:</i>	15 to 2000 Hz (900 to 120,000 cpm) ± 3.0 dB; 20 to 1000 Hz (1,200 to 60,000 cpm) ± 0.9 dB
<i>Transient Temperature Sensitivity</i>	0.0762 mm/s/°C (0.003 in/s/°C), typical, as defined in ISO 5347-18:1993(E)
<i>Amplitude range:</i>	635 mm/s (25 in/s) peak below 680 Hz. 2940 m/s ² (300 g) peak above 680 Hz. Vibration at frequencies above 2 kHz will decrease this range.
<i>Transverse sensitivity:</i>	Less than 5% of Sensitivity
<i>Amplitude linearity:</i>	±2% to 152 mm/s (6 in/s) peak
<i>Mounted resonant frequency:</i>	Greater than 5 kHz
<i>Broadband Noise floor (15Hz to 2kHz)</i>	0.127 mm/s (0.005 in/s) rms nominal
<i>Maximum cable length:</i>	305 metres (1000 feet) with no degradation of signal.

Hazardous Area Approvals

Multiple approvals for hazardous areas certified by Canadian Standards Association (CSA/NRTL/C) in North America and by LCIE in Europe.

<i>North America</i>	Ex ia/AEx ia for Class I Zone 0 IIC T3C @ Ta = 100°C or Class I, Division 1, Groups A, B, C, and D; Class II, Division 1, Groups E, F, and G; and Class III, Division 1, when installed with an approved zener barrier per BN drawing 168077. Ex nL/AEx nL Class 1, Zone 2 IIC Class I, Division 2 (non-incendive), Groups A, B, C, and D when installed per BN drawing 168077.
<i>Europe/GENELEC</i>	EEx ia IIC T4 LCIE 04ATEX6140X EEx nL IIC T4 LCIE 04ATEX6141X Zone 0, Group IIC when installed with an approved zener barrier/galvanic isolators. T4 @ Ta = 100°C.

Environmental Limits

Operating and storage temperature range

<i>Sensing head:</i>	Maximum mounted surface temperature -55°C to +400°C (-67°F to +752°F)
<i>Integral hardline cable:</i>	-55°C to +400° (-67°F to +752°F)
<i>Electronics:</i>	-55°C to +121°C (-67°F to +250°F)
<i>Shock survivability:</i>	24,535 m/s ² (2500 g) peak
<i>Relative humidity:</i>	To 100% non-submerged; case is hermetically sealed.

Physical

Weight (typical):

2 metres: 635 grams (1.40 lb)

4 metres: 794 grams (1.75 lb)

6 metres: 953 grams (2.10 lb)

8 metres: 1111 grams (2.45 lb)

Mounting: See Dimensional Drawings, Figures 1 and 2

Case material: 300 series stainless steel.

Connector: 2-pin Mil-C-5015 receptacle, hermetically-sealed, 304 stainless steel shell.

Polarity: Pin A goes positive with respect to Pin B when the applied velocity is from the base to the top of the transducer.

Bend Radius: Minimum bend radius of 51mm (2.0in)

Note: Please read and understand the User Guide *before* attempting to install and use this product.

Ordering Information

330750-AXX

Option Descriptions

A: Length

2 0	2 metres
4 0	4 metres
6 0	6 metres
8 0	8 metres

330752-AXX

Option Descriptions

A: Length

2 5	2.5 metres
4 0	4 metres
6 0	6 metres
8 0	8 metres

© 2002 Bently Nevada LLC.

® used in this document are registered marks of Bently Nevada LLC.

Dimensional Drawing – 330750 and 330752

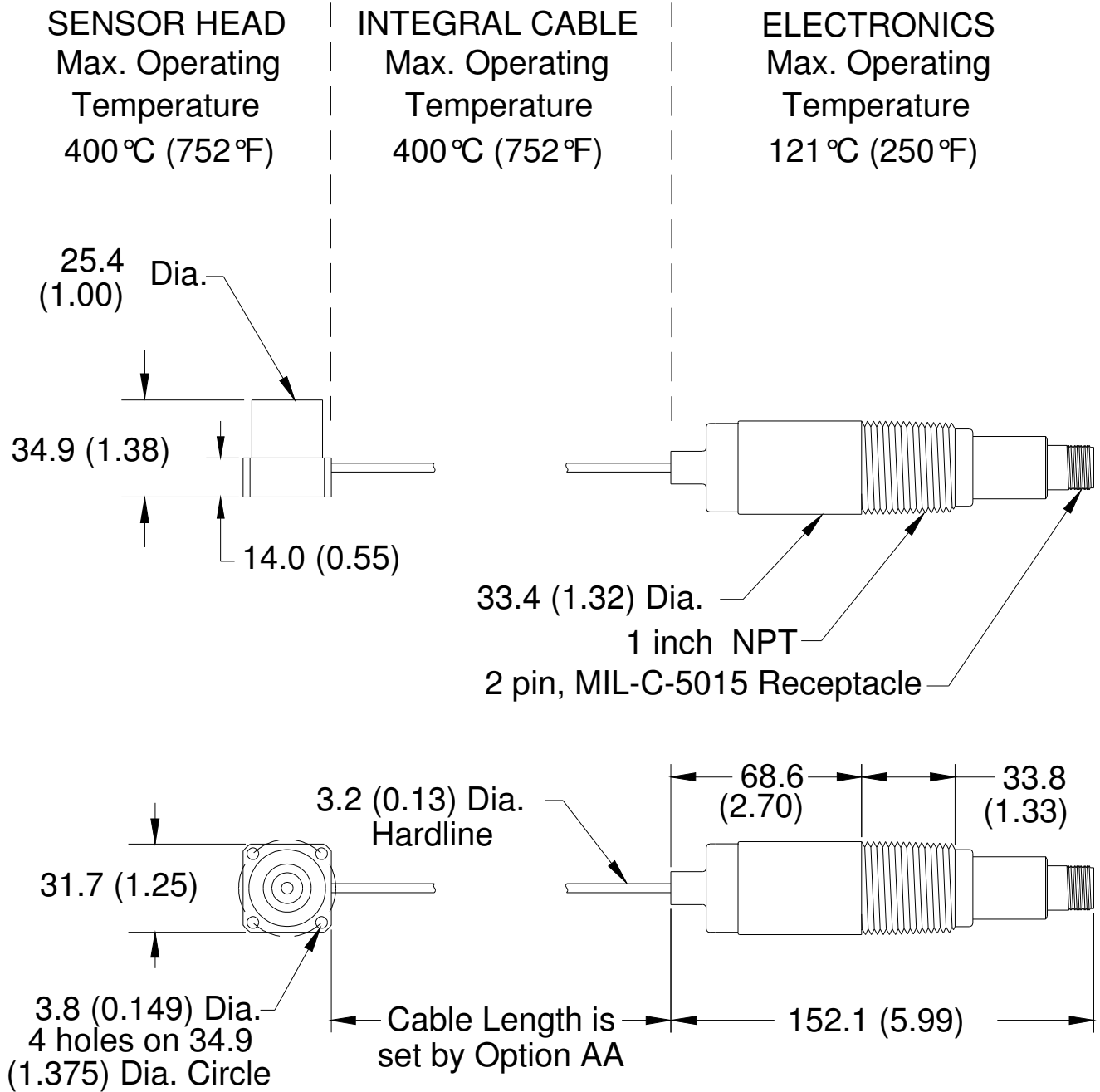

Figure 1: 330750 System Dimensional Drawing
 Dimensions are in millimeters (inches)

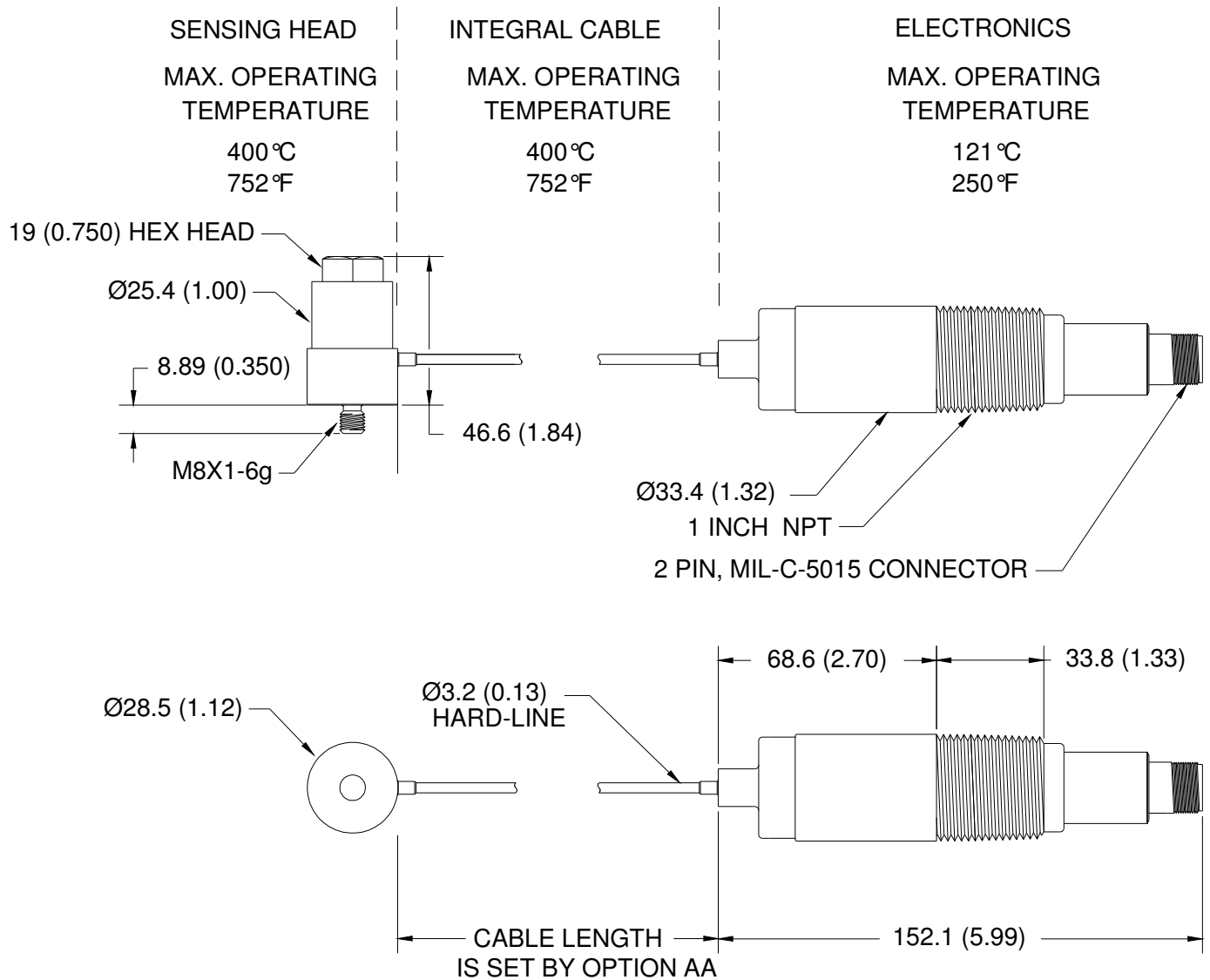

Figure 2: 330752 System Dimensional Drawing
 Dimensions are in millimeters (inches)

Graphs – 330750 and 330752

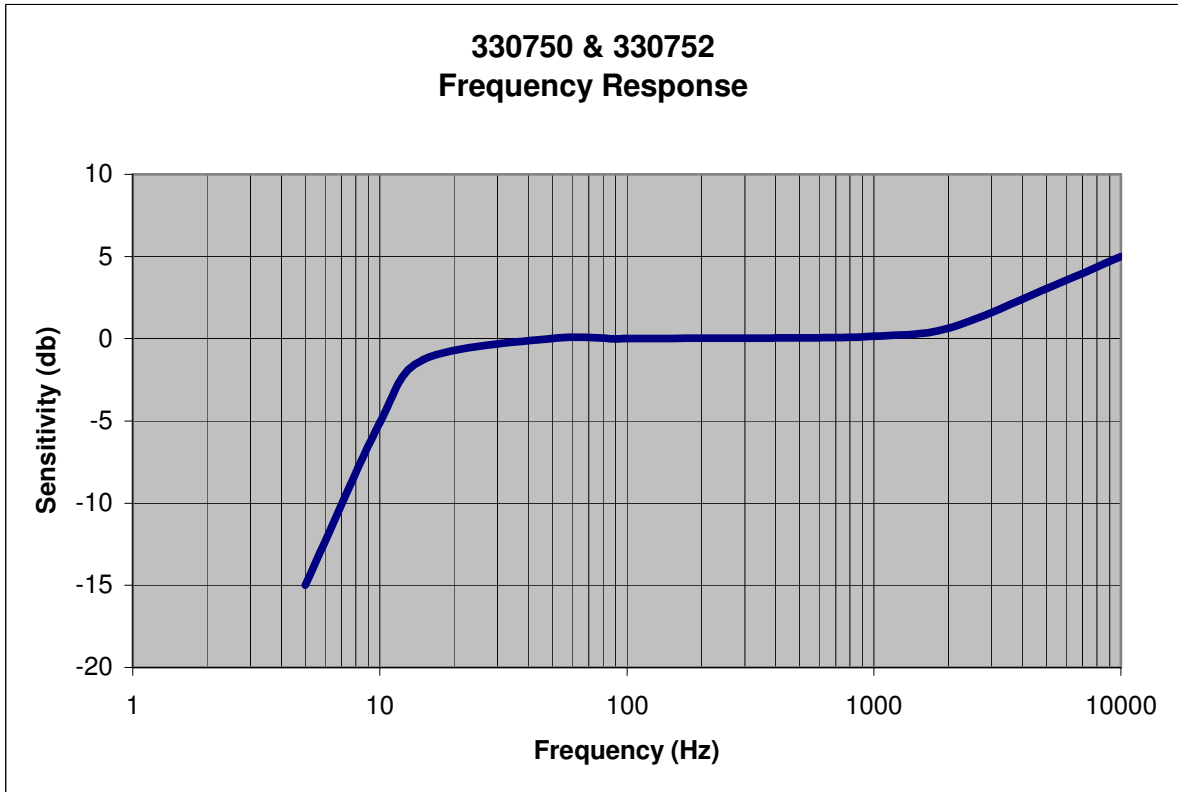

Figure 3: Velocity Amplitude

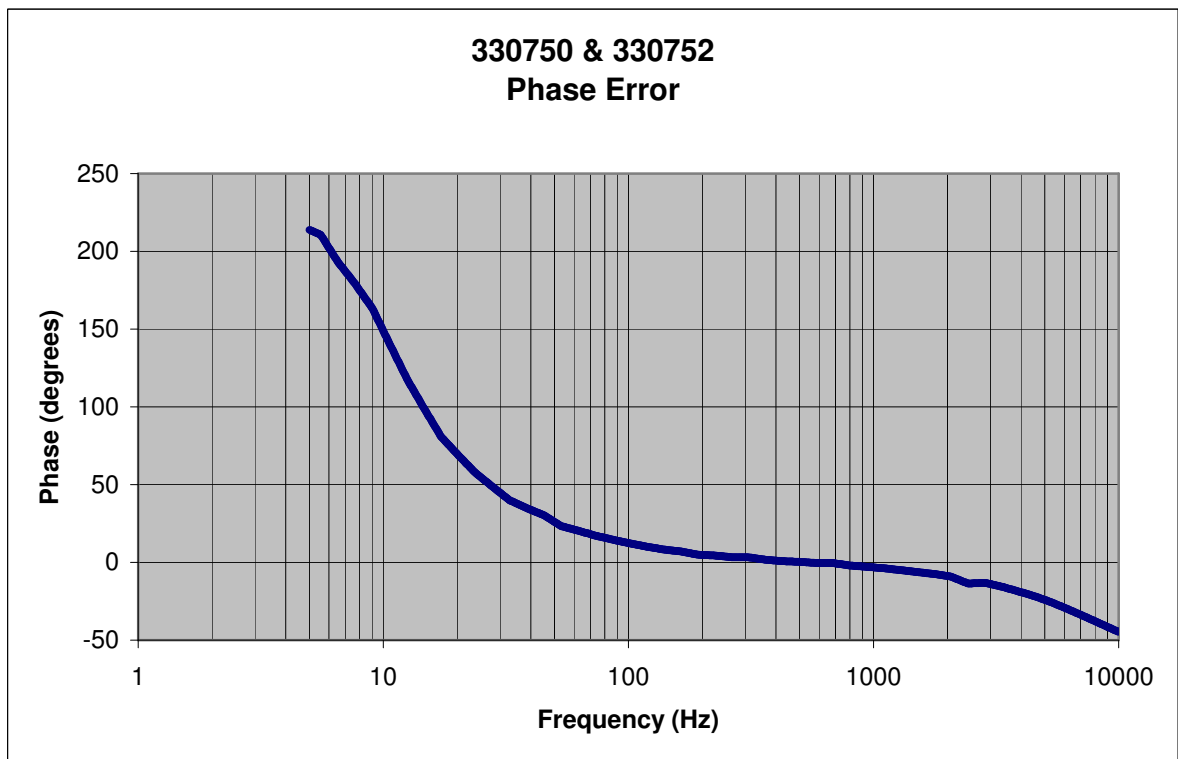
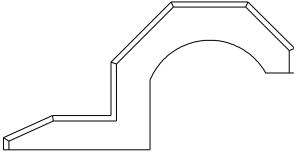
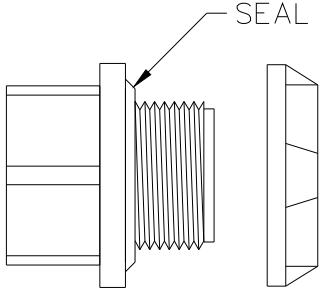
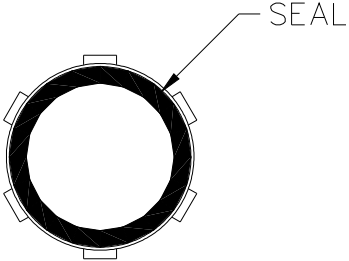
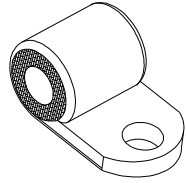
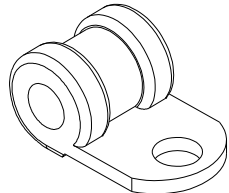

Figure 4: Velocity Phase Error

Table 1: Interconnection Cables and Accessories

APPLICATION	PART NUMBER	DESCRIPTION
*Note: AA - Specifies the length (in feet) of cable required		
Standard Interconnect Cable	9571-AA*	Shielded 0.382 mm ² (22 AWG) cable with a moisture resistant female connector at the HTVS end and ring lugs at the monitor end. Temperature range -29 to 121°C (-20 to 250°F). See Figure 5
Standard Armored Interconnect Cable	84661-AA*	Stainless steel armor over shielded 0.382 mm ² (22 AWG) cable with a moisture resistant female connector at the HTVS end and ring lugs at the monitor end. Temperature range -29 to 121°C (-20 to 250°F). See Figure 6
Right Angle Interconnect Cable	89477-AA*	Shielded 0.963 mm ² (18 AWG) cable with a moisture resistant right angle female connector at the HTVS end and ring lugs at the monitor end. Temperature range -29 to 121°C (-20 to 250°F). See Figure 7
Short Run Interconnect Cable	122129-AA*	Shielded 0.963 mm ² (18 AWG) cable with a moisture resistant female connector at the HTVS end and ring lugs at the monitor end. Temperature range -29 to 121°C (-20 to 250°F). See Figure 8
CE Installation Interconnect Cable (**Required for CE Installations)	02173034	Shielded 0.382 mm ² (22 AWG) cable with a splash-proof boot over a female connector at the HTVS end and flush cut at the monitor end. Temperature range -55 to 125°C (-67 to 257°F). See Figure 9
0.963 mm ² (18 AWG) Bulk Cable	02173006	Shielded twisted pair. Same cable as used on 89477-AA and 122129-AA. Specify number of feet.
0.382 mm ² (22 AWG) Bulk Cable	02173007	Shielded twisted pair. Same cable as used on 9571-AA and 84661-AA. Specify the number of feet. The maximum length that should be used with the HTVS is 305 m (1000 ft)
Spare Connector	00502025	Same connector as used on 9571-AA and 84661-AA
Right Angle Connector	101212-01	Right angle connector kit. Same connector as used on 89477-AA.
330750 & 330752 Manual	135090-01	User Guide
Spare Mating Connector	00531061	Mating plug for 330750 & 330752 Velomitor® System.
Cable Mounting Clamp	00530574	Mating plug clamp to be used with 00531061

<p>Electronics Housing Strap</p>	<p>03818073</p>	<p>1 inch rigid conduit strap for securing the electronics housing.</p> 
<p>Electronics Mounting Hub</p>	<p>03818071</p>	<p>1 inch weather tight hub used to mount the electronics housing in a weatherproof enclosure.</p> 
<p>Seal Ring</p>	<p>03818072</p>	<p>1 inch sealing lock ring used to mount the electronics housing. Two rings are required to mount the electronics.</p> 
<p>Cable Clamp</p>	<p>169546</p>	<p>Stainless steel mesh tie down clamp for the hardline cable. For temperatures greater than 260C (500F).</p> 
<p>Cushioned Cable Clamp</p>	<p>169545</p>	<p>Cushioned tie down clamp for the hardline cable. For temperatures less than 260C (500F).</p> 

PART NUMBER 9571 - (SEE NOTE)

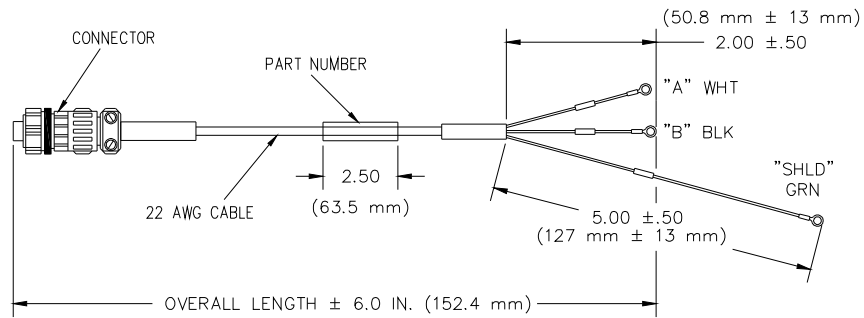

NOTE

ORDER IN INCREMENTS OF 1.0 FOOT (0.30 m)
EXAMPLE: <input type="text"/> <input type="text"/> = 2 FEET (0.60 m)
<input type="text"/> <input type="text"/> = 25 FEET (7.6 m)
MIN LENGTH = 2.0 FEET (0.60 m)
MAX LENGTH = 99 FEET (30 m)

Figure 5: Standard Interconnect Cable

PART NUMBER 84661 - (SEE NOTE)

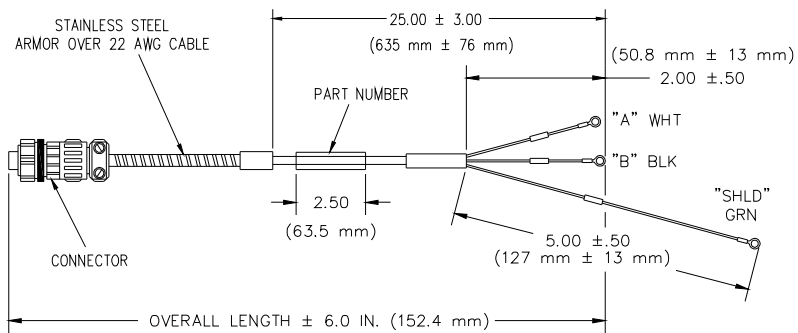

NOTE

ORDER IN INCREMENTS OF 1.0 FOOT (0.30 m)
EXAMPLE: <input type="text"/> <input type="text"/> = 3 FEET (0.91 m)
<input type="text"/> <input type="text"/> = 25 FEET (7.6 m)
MIN LENGTH = 3.0 FEET (0.91 m)
MAX LENGTH = 96 FEET (29 m)

Figure 6: Standard Armored Interconnect Cable

PART NUMBER 89477 - (SEE NOTE)

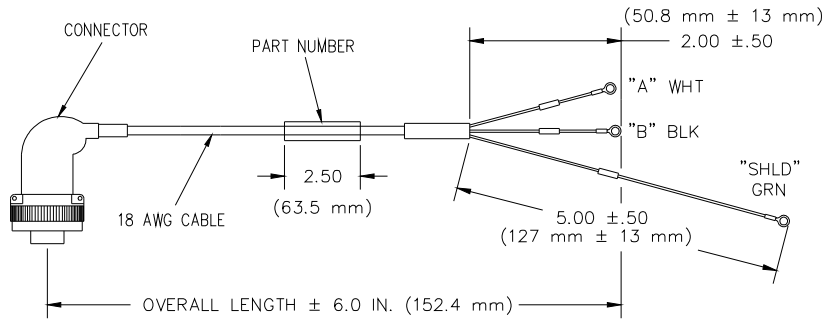

NOTE

ORDER IN INCREMENTS OF 1.0 FOOT (0.30 m)
EXAMPLE: <input type="text"/> <input type="text"/> = 2 FEET (0.60 m)
<input type="text"/> <input type="text"/> = 25 FEET (7.6 m)
MIN LENGTH = 2.0 FEET (0.60 m)
MAX LENGTH = 99 FEET (30 m)

Figure 7: Standard Right Angle Interconnect Cable

PART NUMBER 122129 - (SEE NOTE)

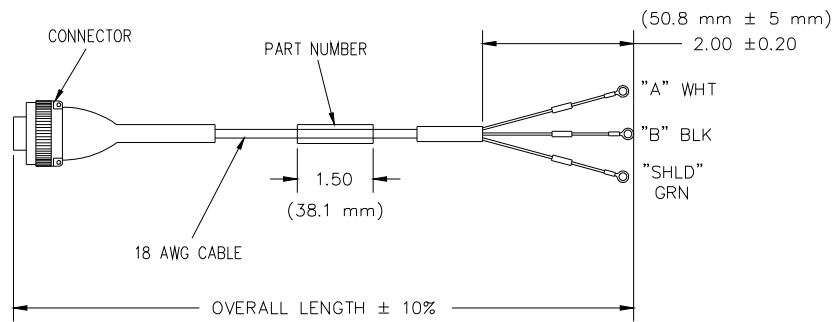

NOTE

ORDER IN INCREMENTS OF 2.0 INCHES (50.8 mm)
EXAMPLE: <input type="text"/> 0 <input type="text"/> 6 = 6 INCHES (152 mm)
<input type="text"/> 2 <input type="text"/> 4 = 24 INCHES (610 mm)
MIN LENGTH = 6.0 INCHES (152 mm)
MAX LENGTH = 24 INCHES (610 mm)

Figure 8: Short Run Interconnect Cable

PART NUMBER 02173034

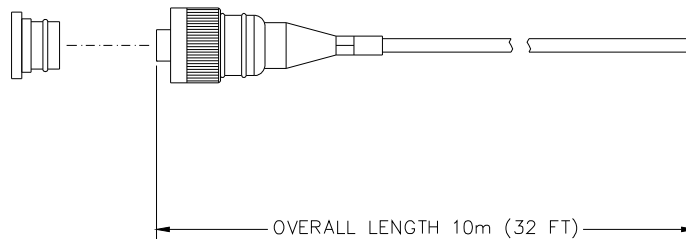

Figure 9: CE Installation Interconnect Cable